



CONCRETE INNOVATIONS!

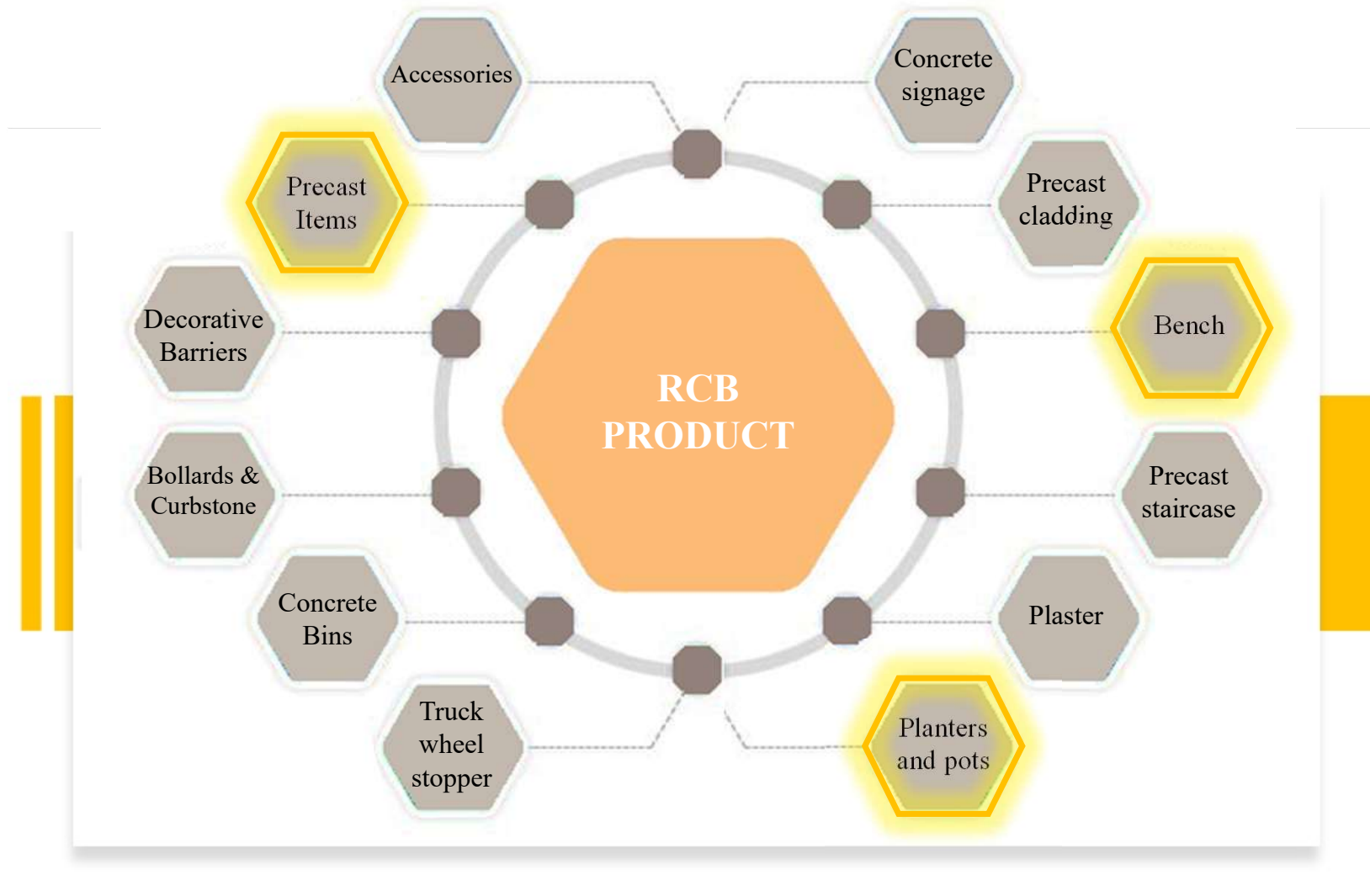

Table of Contents

00	ABOUT US:
01	WET NETWORK (WATER & SEWAGE NETWORKS)
02	CIVIL WORKS (BRIDGES, ROADS & TUNNEL)
03	DRY NETWORKS (ELEC ,CCTV & FIBER OPTIC NETWORK)
04	ARCHITECTURE WORKS (PUBLIC SPACES & URBAN FURNITURE)



Architecture Works



☐ Available Bench

✓ Cube concrete Bench/Type one

TECHNICAL SPECIFICATIONS:

1. Cube bench
2. All dimensions are in mm:
 - ✓ 2000L× 500w ×450H
 - ✓ 500L× 500w ×450H
 - ✓ 2000L× 650w ×450H
3. Concrete grade / UHPC. 120 MPA.
4. Total weight 300 kg.
5. By crane or forklift
6. Finishing type:
 - ✓ Granite
 - ✓ Polished
 - ✓ Acid Wash
 - ✓ Fair Face



- **Project name:** University of Jordan Garden
 - **Year:** 2022



☐ **Available Bench**

✓ **Cube concrete Bench/Type one**



□ Available Bench

✓ Beach Bench/ Type Two



TECHNICAL SPECIFICATIONS:

1. Beach bench.
2. **All dimensions are in mm:**
 - ✓ 1500L× 450w ×450H
3. Concrete grade / UHPC. 120 MPA.
4. Total weight 275 kg.
5. By crane or forklift
6. **Finishing type:**
 - ✓ Granite
 - ✓ Fair Face/Colored

- **Project name:** Dead Sea Corniche
 - **Year:** 2017



☐ Available Bench

✓ School Bench/ Type Two



✓ School concrete bench



☐ Available Bench

✓ Sanad concrete Bench/ Type Three



	Type of finish	Real Examples (Types)		
1	Wood finish			
				
				
2	Plain finish			

Table 1. Different patterns and colors of Precast UHPC Bench.



TECHNICAL SPECIFICATIONS:

1. Sanad bench.
2. All dimensions are in mm:
 - ✓ 1200L × 400w × 450H
3. Concrete grade / UHPC. 120 MPA.
4. Total weight 205 kg.
5. Lifting by crane or forklift.



☐ Available Bench

✓ Sanad concrete Bench/ Type Three

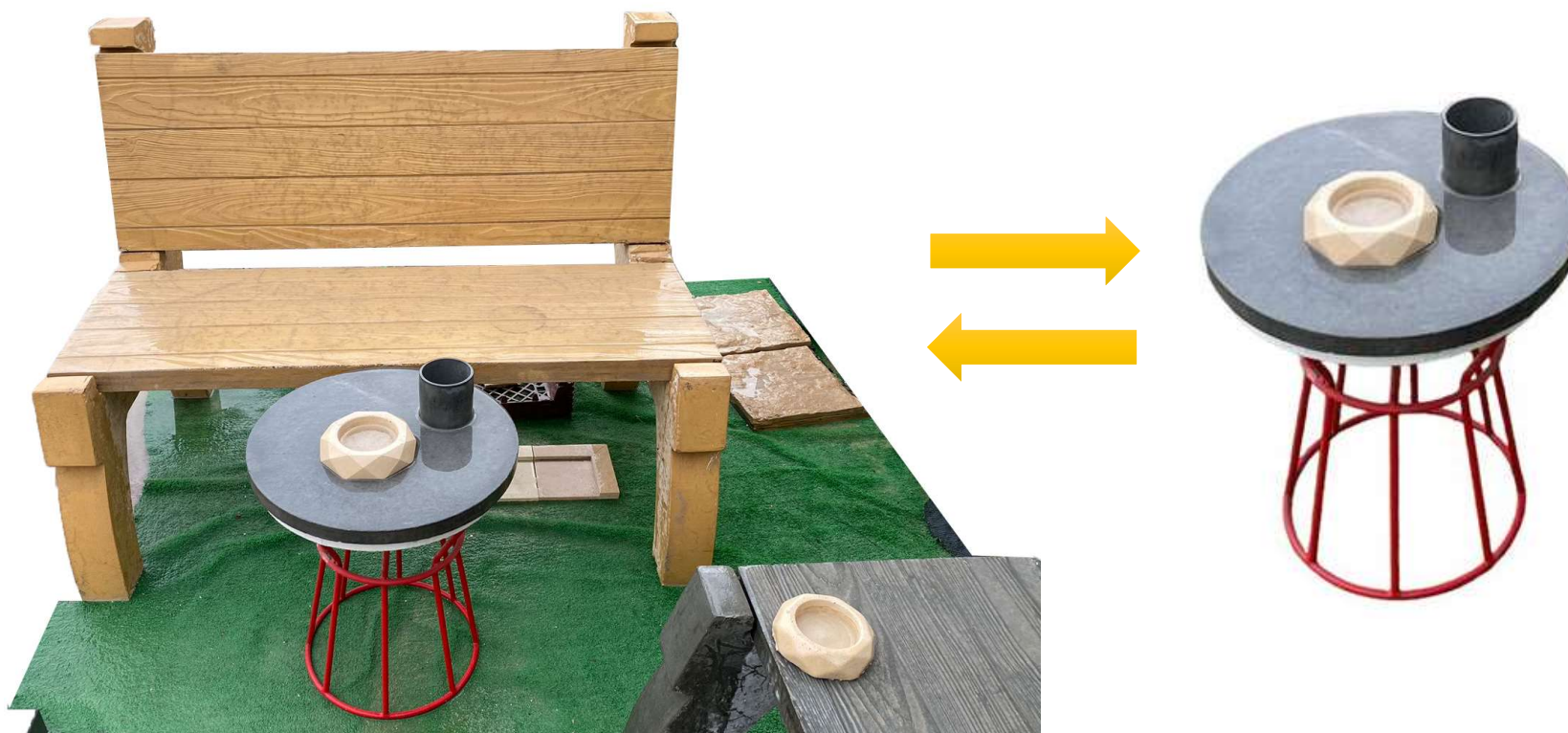

☐ Available Bench

✓ Sanad concrete Bench/ Type Three



□ Available Bench

✓ Simple Bench/ Type Four



TECHNICAL SPECIFICATIONS:

1. Simple bench / School.
2. **All dimensions are in mm:**
 - ✓ 1600L× 400w ×500H
3. Concrete grade / C35.
4. Total weight 280 kg.
5. Lifting by crane or forklift.
6. Fair face finishing

☐ **Available Bench**

✓ Precast concrete Bench



- **Project name:** BRT Project ,Tariq station ,Amman
 - **Year:** 2022



❑ Available Bench

✓ Triangle concrete Bench/ Type Five



TECHNICAL SPECIFICATIONS:

1. Triangle bench.
2. **All dimensions are in mm:**
 - ✓ 1450L× 1450w ×1350H
3. Concrete grade / 120 MPA.
4. Total weight 1000 kg.
5. Lifting by crane or forklift.
6. **Finishing type:**
 - ✓ Polished
 - ✓ Acid wash

✓ BRT Project



□ Available Bench

✓ Loop concrete Bench/ Type Six



TECHNICAL SPECIFICATIONS:

1. Loop bench.
2. **Dimensions- As Required:**
3. Concrete grade / 120 MPA.
4. Total weight 280 kg.
5. Lifting by crane or forklift.
6. **Finishing type:**
 - ✓ Polished
 - ✓ Acid wash



Available Bench

✓ Leopold concrete Bench/ Type Seven

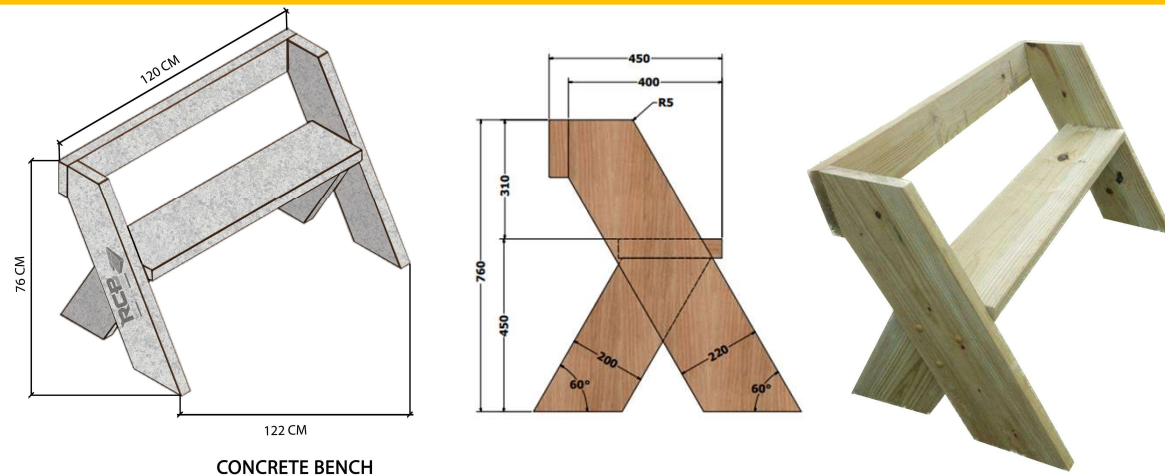

- **Project name:** KASOTC ,Amman
 - **Year:** 2023

TECHNICAL SPECIFICATIONS:

1. Leopold bench.
2. **All dimensions are in mm:**
 - ✓ 1220L× 1200w ×760H
3. Concrete grade / UHPC.
4. Total weight 205 kg.
5. Lifting by crane or forklift.
6. Fair face finishing



☐ Available Bench

- ✓ RaiDan Bench/ Type Eight



TECHNICAL SPECIFICATIONS:

- ✓ RaiDan bench.
- ✓ All dimensions are in mm.
- ✓ Concrete grade / UHPC. 120 MPA.
- ✓ Total weight 205 kg.



☐ Available Bench

✓ RaiDan Collection / Type Eight



✓ New design

▪ The assembled pieces of the bench



❑ Available Table

✓ Ellipsoid Set



TECHNICAL SPECIFICATIONS:

1. Ellipsoid table/Seats.
2. **Dimensions:**
 - Table : 2050L×1100W×750H (1)
 - Seats : 2050L×340W×450H (2)
3. Concrete grade / 120 MPA.
4. Total weight 750 kg.
5. Lifting by crane or forklift.
6. **Finishing type:**
 - ✓ Polished
 - ✓ Acid wash





Trash bins



❑ Available bins

- ✓ Rectangular Trash bin/ Type one



TECHNICAL SPECIFICATIONS:

1. Rectangular bin.
2. All dimensions are in mm:
 - ✓ 660L× 860w ×880H
3. Concrete grade / 120 MPA.
4. Total weight 200 kg.
5. Lifting by crane or forklift.
6. Finishing type:
 - ✓ Granite
 - ✓ Polished
 - ✓ Acid Wash
 - ✓ Fair Face



☐ Available bins

✓ Square Trash Bin/ Type two

TECHNICAL SPECIFICATIONS:

1. Square bin.
2. **All dimensions are in mm:**
 - ✓ 600L × 600w × 640H
3. Concrete grade / 120 MPA.
4. Total weight 200 kg.
5. Lifting by crane or forklift.
6. **Finishing type:**
 - ✓ Granite
 - ✓ Polished
 - ✓ Acid Wash
 - ✓ Fair Face





Planters and pots



□ Available planters and pots

✓ Oval Pots concrete/ Type one



TECHNICAL SPECIFICATIONS:

1. Oval Pots.
2. All dimensions are in mm:
 - ✓ 290H×290D
 - ✓ 350H×350D
 - ✓ 400H×400D
 - ✓ 480H×480D
 - ✓ 600H×600D
 - ✓ 640H×640D
 - ✓ 900H×900D
3. Concrete grade / 120 MPA.
4. Total weight (different size).
5. Lifting by crane or forklift.
6. Finishing type:
 - ✓ Granite
 - ✓ Acid Wash
 - ✓ Fair Face

✓ Public projects



❑ Available planters and pots

✓ Semicircular pots concrete/ Type two

TECHNICAL SPECIFICATIONS:

1. Semicircular pots.
1. **2. All dimensions are in mm:**
 - ✓ 220H×410D
 - ✓ 310H×610D
3. Concrete grade / 120 MPA.
4. Total weight (different size).
5. Lifting by crane or forklift.
6. **Finishing type:**
 - ✓ Granite
 - ✓ Acid Wash
 - ✓ Fair Face



❑ Available planters and pots

✓ Bowl planter concrete/ Type three



TECHNICAL SPECIFICATIONS:

1. Bowl planter.
2. All dimensions are in mm:
 - ✓ 1200D×300H
3. Concrete grade / 120 MPA.
4. Total weight 150 kg.
5. Lifting by crane or forklift.
6. Finishing type:
 - ✓ Granite
 - ✓ Acid Wash
 - ✓ Fair Face

✓ Arab Bank
project



❑ Available planters and pots

✓ Cube planter concrete/ Type four

TECHNICAL SPECIFICATIONS:

1. Cube planter.
2. All dimensions are in mm:
 - ✓ 650L×650W×550H
3. Concrete grade / 120 MPA.
4. Total weight 100 kg.
5. Lifting by crane or forklift.
6. Finishing type:
 - ✓ Granite
 - ✓ Acid Wash
 - ✓ Fair Face



❑ Available planters and pots

✓ Loop Seat planter concrete/ Type five



TECHNICAL SPECIFICATIONS:

1. Loop Seat planter concrete.
2. **All dimensions are in mm:**
 - ✓ External Dia.3000mm
 - ✓ External Dia. 3400mm
3. Concrete grade / 120 MPA.
4. Total weight 240 kg.
5. Lifting by crane or forklift.
6. **Finishing type:**
 - ✓ Granite
 - ✓ Acid Wash
 - ✓ Fair Face
 - ✓ Polished

✓ New Design



❑ Available planters and pots

- ✓ Cylindrical planter concrete/ Type six

TECHNICAL SPECIFICATIONS:

1. Cylindrical planter.
2. All dimensions are in mm:
 - ✓ 445D×605H
3. Concrete grade / 120 MPA.
4. Total weight 130 kg.
5. Lifting by crane or forklift.
6. Finishing type:
 - ✓ Granite
 - ✓ Acid Wash
 - ✓ Fair Face



□ Available planters and pots

✓ Tree Grating / Type seven

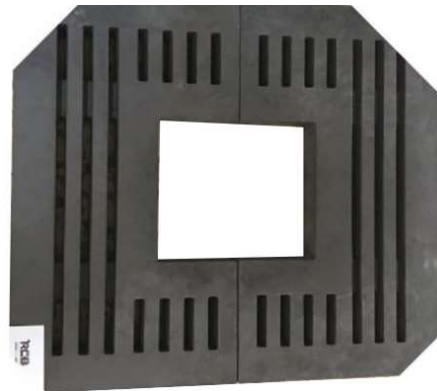
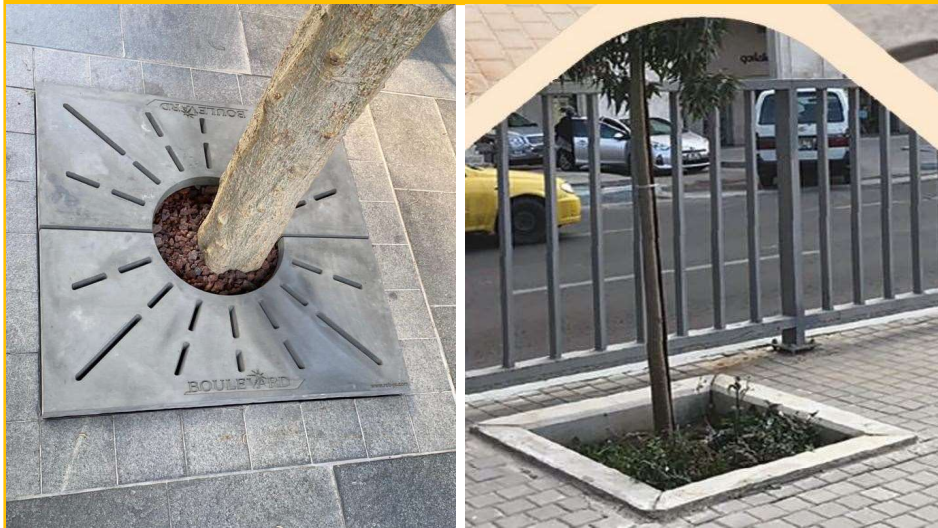

TECHNICAL SPECIFICATIONS:

1. Tree Grating.
2. All dimensions are in mm:
 - ✓ 900L×900W
3. Concrete grade / 120 MPA.
4. Total weight 120 kg.
5. Lifting by Hand.
6. Finishing type:
 - ✓ Granite
 - ✓ Acid Wash
 - ✓ Fair Face
 - ✓ Polished

✓ Public projects





Precast Items



☐ Available Precast Items

- ✓ Circle Footpath Landscape Concrete



TECHNICAL SPECIFICATIONS:

1. Circle Footpath concrete.
2. **All dimensions are in mm:**
 - ✓ D1:1000mm
 - ✓ D2:750mm
 - ✓ D3: 500 mm
 - ✓ D4: 250mm
3. Concrete grade / 120 MPA.
4. Total weight (different size).
5. Lifting by crane or forklift.
6. **Finishing type:**
 - ✓ Acid Wash
 - ✓ Fair Face

- ✓ Public projects



☐ Available Precast Items

- ✓ Luminous bollard Concrete

TECHNICAL SPECIFICATIONS:

1. Luminous bollard Concrete.
2. **All dimensions are in mm:**
 - ✓ 1200H×200W×200D
3. Concrete grade / 120 MPA.
4. Total weight 190 kg.
5. Lifting by crane or forklift.
6. **Finishing type:**
 - ✓ Granite
 - ✓ Acid Wash
 - ✓ Fair Face
 - ✓ Polished



☐ Available Precast Items

✓ Circular Bollard Concrete



TECHNICAL SPECIFICATIONS:

1. Circular Bollard Concrete.
2. All dimensions are in mm:
 - ✓ 1100H×160D
3. Concrete grade / 120 MPA.
4. Total weight (different size).
5. Lifting by crane or forklift.
6. Finishing type:
 - ✓ Acid Wash
 - ✓ Fair Face

✓ Public projects

